



## FILM BLADES MADE BY LUTZ – HIGH-PERFORMANCE BLADES FOR HIGH-PERFORMANCE FILM

CUSTOM BLADES

**FILM AND FOIL**

CHEMICAL FIBRES AND FIBREGLASS

MEDICAL

FOOD

DIY

AUTOMOTIVE

TEXTILE

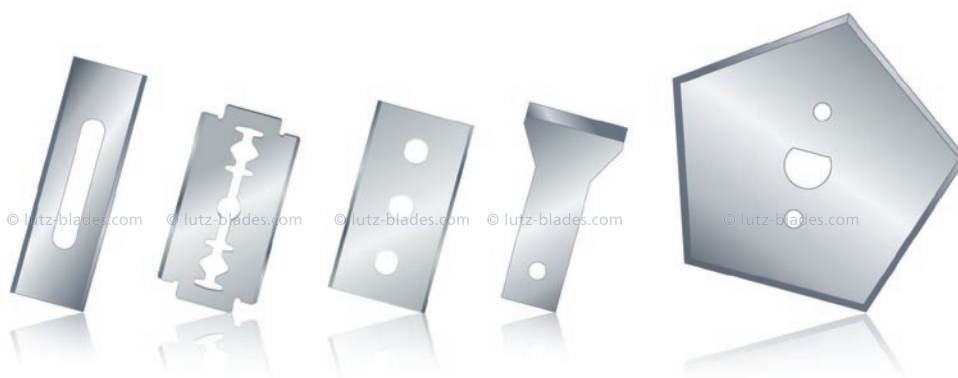

**FILM BLADES MADE BY LUTZ –  
HIGH-PERFORMANCE BLADES FOR HIGH-PERFORMANCE FILM**





Tough film which is also highly elastic? Additives present? Impact loads and lateral forces? There is no doubt that film manufacture is a high-performance process.





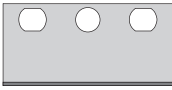

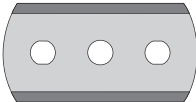
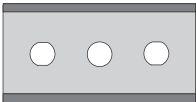
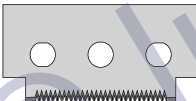



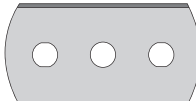











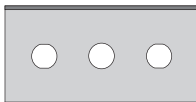



LUTZ manufactures high-grade special-purpose blades for industrial applications. We make use of a wide range of steel qualities, tungsten carbide and ceramics.







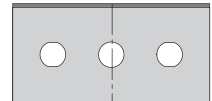

In terms of material, heat-treatment and cutter geometry, our blades are designed specifically to meet the application needs of the user.

CUSTOM BLADES | FILM AND FOIL | CHEMICAL FIBRE AND FIBREGLASS | MEDICAL | FOOD | DIY | AUTOMOTIVE | TEXTILE

**Proprietary rights:** The owner of all the brandnames used by LUTZ on its websites is LUTZ GmbH & Co. KG, Solingen, Germany. Third Parties are explicitly prohibited from using any of the brandnames, logos or marks of any kind found there. This applies in particular to the internationally registered trademark "LUTZ BLADES exactly", which consists of words and graphic symbols. LUTZ will pursue all violations against trademark law regarding its trademarks.  
**Copyright:** © COPYRIGHT LUTZ GmbH & Co. KG, Solingen, Germany. All rights reserved. Copy, photos, graphics, technical drawings, layouts and other information used in all our publications and their arrangements on our LUTZ website are subject to copyright and other proprietary rights.  
LUTZ allows the content of its websites to be viewed and downloaded exclusively for non-commercial use. This content may not be duplicated, presented, distributed or in any way used for publication of any kind or commercial use. This content may not be modified or used on other websites or networked computers without prior written approval by LUTZ GmbH & Co. KG.  
E & OE. Subject to our general terms & conditions on the Internet at [www.lutz-blades.com](http://www.lutz-blades.com).

Ref.	Length (mm)	Width (mm)	Thickn. (mm)
	39.0	18.8	0.30
	34.0	8.0	0.30
	43.0	22.2	0.40
	43.0	22.2	0.40
	43.0	21.5	0.30
	39.0	18.9	0.25

Ref.	Length (mm)	Width (mm)	Thickn. (mm)
	43.0	22.2	0.06
			0.08
			0.10
			0.13
			0.15
			0.20
			0.30
			0.40
			0.65
			0.90
	43.0	22.2	0.10
			0.15
			0.30
	43.0	22.2	0.06
			0.08
			0.10
			0.13
			0.15
			0.20
			0.30
			0.40
			0.65
			0.90
	38.0		0.10
			0.15
			0.20
			0.30
			0.40

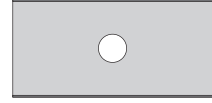
Ref.	Length (mm)	Width (mm)	Thickn. (mm)
	43.0	22.2	0.10
			0.15
			0.20
			0.30
			0.40
	43.0	22.2	0.10
			0.15
	40.0	18.8	0.25
	40.0	22.0	0.10

**AND THIS IS HOW YOU CAN BENEFIT FROM LUTZ BLADES**

- » Cleanly cut edge with no edge build-up
- » Less cutting dust
- » High cutting speeds
- » Greater productivity thanks to fewer blade changes



CUSTOM BLADES | FILM AND FOIL | CHEMICAL FIBRE AND FIBREGLASS | MEDICAL | FOOD | DIY | AUTOMOTIVE | TEXTILE





**Proprietary rights:** The owner of all the brandnames used by LUTZ on its websites is LUTZ GmbH & Co. KG, Solingen, Germany. Third Parties are explicitly prohibited from using any of the brandnames, logos or marks of any kind found there. This applies in particular to the internationally registered trademark "LUTZ BLADES exactly", which consists of words and graphic symbols. LUTZ will pursue all violations against trademark law regarding its trademarks.

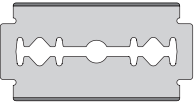
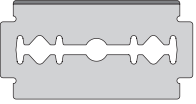

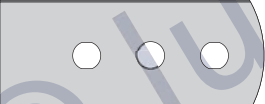
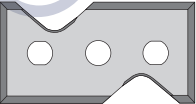
**Copyright:** © COPYRIGHT LUTZ GmbH & Co. KG, Solingen, Germany. All rights reserved. Copy, photos, graphics, technical drawings, layouts and other information used in all our publications and their arrangements on our LUTZ website are subject to copyright and other proprietary rights.

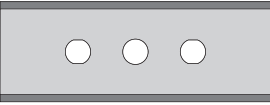
LUTZ allows the content of its websites to be viewed and downloaded exclusively for non-commercial use. This content may not be duplicated, presented, distributed or in any way used for publication of any kind or commercial use. This content may not be modified or used on other websites or networked computers without prior written approval by LUTZ GmbH & Co. KG.

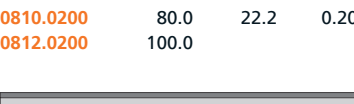
E & OE. Subject to our general terms & conditions on the Internet at [www.lutz-blades.com](http://www.lutz-blades.com).

Ref.	Length (mm)	Width (mm)	Thickn. (mm)
	43.0	22.2	0.10
0420.0150			0.15
0420.0200			0.20
0420.0300			0.30
	43.0	22.2	0.20
0436.0200			
	43.5	19.0	0.10
0425.0100			0.10
0428.0200			0.20
	52.7	22.2	0.15
0520.0150			
	43.0	22.0	1.00
0470.1000			

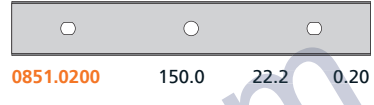
Ref.	Length (mm)	Width (mm)	Thickn. (mm)
	60.0	22.2	0.10
0600.0130			0.13
0600.0150			0.15
0600.0200			0.20
0600.0300			0.30
0600.0400			0.40
0500.0130	50.0		0.13
0500.0150			0.15
0500.0300			0.30
	80.0	22.2	0.20
0800.0200			0.20
0800.0300			0.30
	80.0	22.2	0.20
0810.0200			
	100.0	22.2	0.20
0812.0200			
	94.0	22.2	0.30
0850.0300			

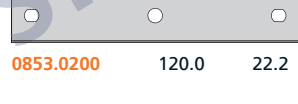
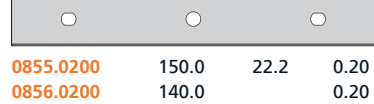
Ref.	Length (mm)	Width (mm)	Thickn. (mm)
	150.0	22.2	0.20
0851.0200			
	118.0	22.2	0.15
0852.0150			
	120.0	22.2	0.20
0853.0200			
	150.0	22.2	0.20
0855.0200			
0856.0200	140.0		0.20
0857.0150	125.0		0.15

exactly WHAT YOU NEED FOR ALL FILM CUTTING APPLICATIONS

LUTZ Americas | 1928 Woodman Center Dr. | 45420 Kettering, OH | USA  
Phone: +1 937 2933662 | Fax: +1 937 2934280  
E-Mail: [davidw@lutz-blades.net](mailto:davidw@lutz-blades.net) | [www.lutz-blades.com](http://www.lutz-blades.com)

LUTZ GmbH & Co. KG | Wuppertaler Strasse 251 | DE-42653 Solingen | Germany  
Phone: +49 212 5966-0 | Fax: +49 212 5966-26  
E-Mail: [info@lutz-blades.com](mailto:info@lutz-blades.com) | [www.lutz-blades.com](http://www.lutz-blades.com)

**IMPROVING ON THE NEAR-PERFECT – HARD COATINGS EXTEND LIFETIMES**





As a supplier of high-quality special blades, we pride ourselves on being able to offer a wide selection of coatings (TiN, TiC, TiAlN, CrN, DLC, TiCN, PTFE etc.), which



are designed to extend the lifetimes of the blades considerably when cutting white film, aluminium foil, filled LLDPE and PET film, magnetic tape, OPP and BOPP

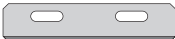

film and other types of film. We will be pleased to advise you.

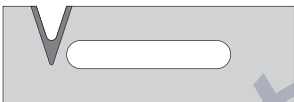
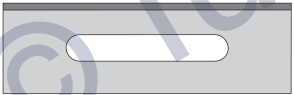
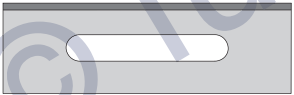
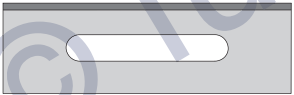
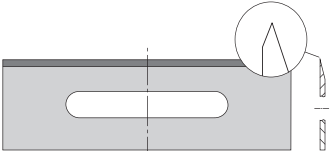
CUSTOM BLADES | FILM AND FOIL | CHEMICAL FIBRE AND FIBREGLASS | MEDICAL | FOOD | DIY | AUTOMOTIVE | TEXTILE

**Proprietary rights:** The owner of all the brandnames used by LUTZ on its websites is LUTZ GmbH & Co. KG, Solingen, Germany. Third Parties are explicitly prohibited from using any of the brandnames, logos or marks of any kind found there. This applies in particular to the internationally registered trademark "LUTZ BLADES exactly", which consists of words and graphic symbols. LUTZ will pursue all violations against trademark law regarding its trademarks.  
**Copyright:** © COPYRIGHT LUTZ GmbH & Co. KG, Solingen, Germany. All rights reserved. Copy, photos, graphics, technical drawings, layouts and other information used in all our publications and their arrangements on our LUTZ website are subject to copyright and other proprietary rights.  
LUTZ allows the content of its websites to be viewed and downloaded exclusively for non-commercial use. This content may not be duplicated, presented, distributed or in any way used for publication of any kind or commercial use. This content may not be modified or used on other websites or networked computers without prior written approval by LUTZ GmbH & Co. KG.  
E & OE. Subject to our general terms & conditions on the Internet at [www.lutz-blades.com](http://www.lutz-blades.com).

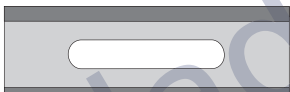
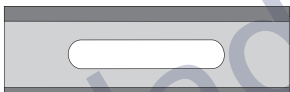
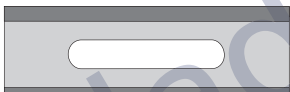
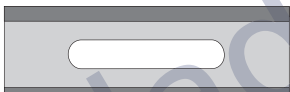
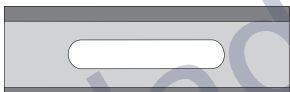
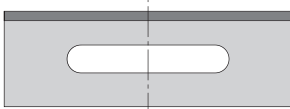
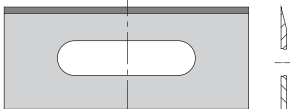
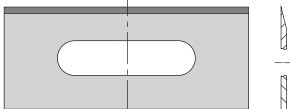
Ref.	Length (mm)	Width (mm)	Thickn. (mm)
 <b>6030.0254</b>	38.0	8.0	0.25
 <b>0707.0380</b>	57.0	19.1	0.38
 <b>0710.0400</b>	57.7	18.8	0.40
 <b>0697.0400</b>	28.5	19.1	0.40
 <b>4307.1000</b>	57.7	19.1	1.00
 <b>0711.0430</b>	57.0	19.1	0.43
 <b>0713.0630</b>	57.2	19.1	0.63
 <b>0709.0380</b>	57.0	18.8	0.38
 <b>0730.1000</b>	57.7	19.1	1.00

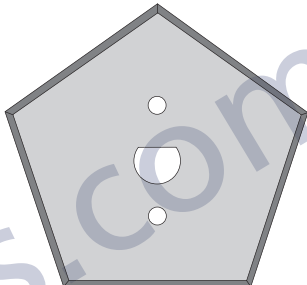
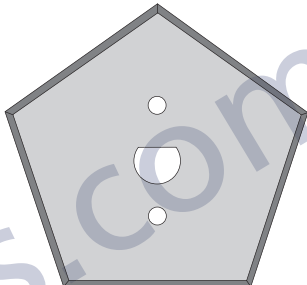
Ref.	Length (mm)	Width (mm)	Thickn. (mm)
 <b>0700.0400</b>	59.0	18.8	0.40
 <b>0698.0400</b>	59.0	18.8	0.40
 <b>0703.0380</b>	57.0	19.1	0.38
 <b>0705.0400</b>		18.8	0.40
 <b>0714.0500</b>			0.50
 <b>0715.0900</b>	59.0		0.90
 <b>0729.0630</b>	57.0	19.1	0.60
 <b>0717.0630</b>	57.2	19.1	0.63
 <b>0724.0300</b>	45.0	18.8	0.30
 <b>0718.0400</b>			0.40

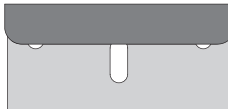
Ref.	Length (mm)	Width (mm)	Thickn. (mm)
 <b>2650.0530</b>	41.4	63.8	0.53
 <b>2651.0530</b>	40.9	63.0	0.53
 <b>0308.0228</b>	39.8	19.5	0.23
 <b>0300.0250</b>	40.0	19.9	0.25

exactly WHAT YOU NEED FOR ALL FILM CUTTING APPLICATIONS

LUTZ Americas | 1928 Woodman Center Dr. | 45420 Kettering, OH | USA  
Phone: +1 937 2933662 | Fax: +1 937 2934280  
E-Mail: [davidw@lutz-blades.net](mailto:davidw@lutz-blades.net) | [www.lutz-blades.com](http://www.lutz-blades.com)

LUTZ GmbH & Co. KG | Wuppertaler Strasse 251 | DE-42653 Solingen | Germany  
Phone: +49 212 5966-0 | Fax: +49 212 5966-26  
E-Mail: [info@lutz-blades.com](mailto:info@lutz-blades.com) | [www.lutz-blades.com](http://www.lutz-blades.com)

**LUTZ BLADES - CIRCULAR BLADES AND CUTTERS**

Thanks to their razor-sharp cutting edges, their excellent flatness and hardening, our circular blades and cutters have been acknowledged for years as being among the best.

Something we keep working on every day! To keep your production rolling.

CUSTOM BLADES | FILM AND FOIL | CHEMICAL FIBRE AND FIBREGLASS | MEDICAL | FOOD | DIY | AUTOMOTIVE | TEXTILE

**Proprietary rights:** The owner of all the brandnames used by LUTZ on its websites is LUTZ GmbH & Co. KG, Solingen, Germany. Third Parties are explicitly prohibited from using any of the brandnames, logos or marks of any kind found there. This applies in particular to the internationally registered trademark "LUTZ BLADES exactly", which consists of words and graphic symbols. LUTZ will pursue all violations against trademark law regarding its trademarks.  
**Copyright:** © COPYRIGHT LUTZ GmbH & Co. KG, Solingen, Germany. All rights reserved. Copy, photos, graphics, technical drawings, layouts and other information used in all our publications and their arrangements on our LUTZ website are subject to copyright and other proprietary rights.  
 LUTZ allows the content of its websites to be viewed and downloaded exclusively for non-commercial use. This content may not be duplicated, presented, distributed or in any way used for publication of any kind or commercial use. This content may not be modified or used on other websites or networked computers without prior written approval by LUTZ GmbH & Co. KG.  
 E & OE. Subject to our general terms & conditions on the Internet at [www.lutz-blades.com](http://www.lutz-blades.com).

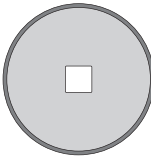
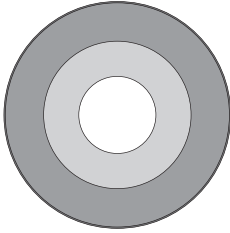
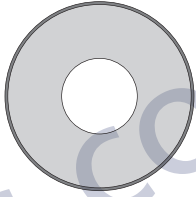
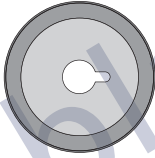
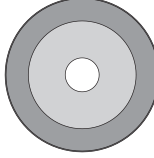
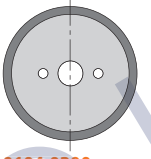
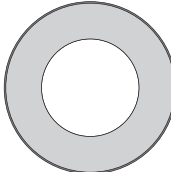
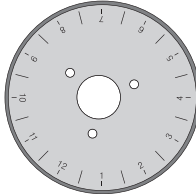
Ref.	ø OD (mm)	ø ID (mm)	Thickn. (mm)	Ref.	ø OD (mm)	ø ID (mm)	Thickn. (mm)	Ref.	ø OD (mm)	ø ID (mm)	Thickn. (mm)
	40.0	7.0	0.30		100.0	34.0	1.00		50.0	20.0	0.20
0108.0300	26.0			0125.1000				0145.0200			
0114.0300					45.0	10.0	0.50		100.0	22.0	1.00
0129.0100	30.0	10.0	0.10	0119.0500				0115.1000			
	30.0	5.0	0.30		30.0	17.0	0.10		44.0	10.0	0.30
0104.0300				0120.0100	50.0	25.0	0.15	0105.0300			
				0126.0150	70.0	48.0	0.15				
				0175.0150							

**BLADES IN CUTTING MACHINES? THAT MAKES US PARTNERS.**

We provide replacement blades for the following makes of machines:

- » Windmüller & Hölscher<sup>®</sup>
- » Reifenhäuser<sup>®</sup>
- » Starlinger<sup>®</sup>
- » Kampf<sup>®</sup>
- » Barmag<sup>®</sup>

- » Brückner<sup>®</sup>
- » SML/Lenzing<sup>®</sup>
- » Atlas<sup>®</sup>
- » Goebel<sup>®</sup>
- ... and more

CUSTOM BLADES | FILM AND FOIL | CHEMICAL FIBRE AND FIBREGLOSS | MEDICAL | FOOD | DIY | AUTOMOTIVE | TEXTILE

**Proprietary rights:** The owner of all the brandnames used by LUTZ on its websites is LUTZ GmbH & Co. KG, Solingen, Germany. Third Parties are explicitly prohibited from using any of the brandnames, logos or marks of any kind found there. This applies in particular to the internationally registered trademark "LUTZ BLADES exactly", which consists of words and graphic symbols. LUTZ will pursue all violations against trademark law regarding its trademarks.

**Copyright:** © COPYRIGHT LUTZ GmbH & Co. KG, Solingen, Germany. All rights reserved. Copy, photos, graphics, technical drawings, layouts and other information used in all our publications and their arrangements on our LUTZ website are subject to copyright and other proprietary rights.

LUTZ allows the content of its websites to be viewed and downloaded exclusively for non-commercial use. This content may not be duplicated, presented, distributed or in any way used for publication of any kind or commercial use. This content may not be modified or used on other websites or networked computers without prior written approval by LUTZ GmbH & Co. KG.

E & OE. Subject to our general terms & conditions on the Internet at [www.lutz-blades.com](http://www.lutz-blades.com).

Ref.	Length (mm)	Width (mm)	Thickn. (mm)
 <b>0021.0400</b>	21.0	8.0	0.40
 <b>0023.0500</b>	14.0	12.0	0.50
 <b>0016.0500</b>	19.0	16.9	0.50
 <b>0010.0400</b>	23.0	21.0	0.40
<b>0014.0500</b>		0.50	
 <b>0012.0500</b>	23.8	21.0	0.50
<b>0013.0200</b>		0.20	
 <b>0441.0150</b>	43.0	22.2	0.15

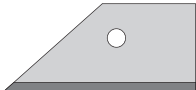
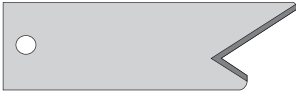
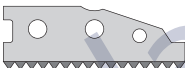
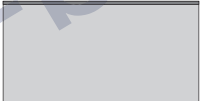
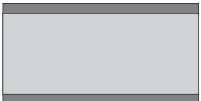
Ref.	Length (mm)	Width (mm)	Thickn. (mm)
 <b>1052.0680</b>	42.4	19.0	0.68
 <b>0918.0800</b>	65.0	19.0	0.80
 <b>4011.0880</b>	40.0	14.0	0.88
 <b>0801.0300</b>	43.0	22.2	0.30
 <b>0802.0400</b>	43.0	22.2	0.40

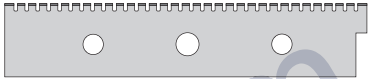
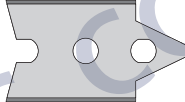
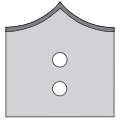
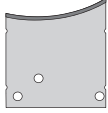
Ref.	Length (mm)	Width (mm)	Thickn. (mm)
 <b>0840.0300</b>	99.0	20.0	0.30
 <b>0220.0300</b>	39.5	22.2	0.30
 <b>1240.0380</b>	24.0	25.4	0.38
 <b>1350.0400</b>	24.3	22.0	0.40

## LUTZ BLADES MANUFACTURES OVER 500 DIFFERENT CUSTOM BLADES TO CUSTOMERS' DRAWINGS

Our product range consists of serrated, toothed, wavy, curved, notched, pointed, multi-sided, crimped special-purpose blades or combinations of several shapes and geometries.

Thanks to rapid prototyping and our highly flexible manufacturing technologies we are in a position to manufacture small (and even very small) runs of custom blades in only a few days!









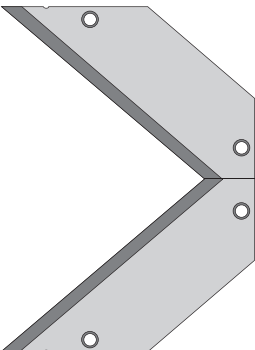
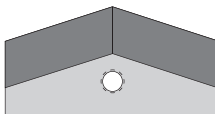
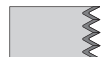

CUSTOM BLADES | FILM AND FOIL | CHEMICAL FIBRE AND FIBREGLASS | MEDICAL | FOOD | DIY | AUTOMOTIVE | TEXTILE

**Proprietary rights:** The owner of all the brandnames used by LUTZ on its websites is LUTZ GmbH & Co. KG, Solingen, Germany. Third Parties are explicitly prohibited from using any of the brandnames, logos or marks of any kind found there. This applies in particular to the internationally registered trademark "LUTZ BLADES exactly", which consists of words and graphic symbols. LUTZ will pursue all violations against trademark law regarding its trademarks.

**Copyright:** © COPYRIGHT LUTZ GmbH & Co. KG, Solingen, Germany. All rights reserved. Copy, photos, graphics, technical drawings, layouts and other information used in all our publications and their arrangements on our LUTZ website are subject to copyright and other proprietary rights.

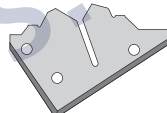
LUTZ allows the content of its websites to be viewed and downloaded exclusively for non-commercial use. This content may not be duplicated, presented, distributed or in any way used for publication of any kind or commercial use. This content may not be modified or used on other websites or networked computers without prior written approval by LUTZ GmbH & Co. KG.

E & OE. Subject to our general terms & conditions on the internet at [www.lutz-blades.com](http://www.lutz-blades.com).

Ref.	Length (mm)	Width (mm)	Thickn. (mm)	Ref.	Length (mm)	Width (mm)	Thickn. (mm)	Ref.	Length (mm)	Width (mm)	Thickn. (mm)
	92.0	67.9	0.50		50.0	25.0	2.00		21.5	11.5	0.70
	29.0	5.0	0.40		12.0	4.1	0.40		41.0	5.6	0.50
	90.0	14.0	2.50		50.0	20.0	0.40		32.0	32.0	0.70
	18.8	4.8	0.50		7.0	7.0	0.68		23.0	15.6	0.65
	413.0	40.0	1.00		10.3	12.0	1.20				

**LUTZ INDUSTRIAL BLADES HAVE THE FOLLOWING CHARACTERISTICS**

- » The best materials
- » Adherence to the closest tolerances
- » Optimum hardness
- » Selected high-performance coatings











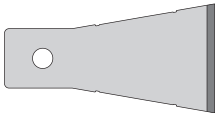

CUSTOM BLADES | FILM AND FOIL | CHEMICAL FIBRE AND FIBREGLOSS | MEDICAL | FOOD | DIY | AUTOMOTIVE | TEXTILE

**Proprietary rights:** The owner of all the brandnames used by LUTZ on its websites is LUTZ GmbH & Co. KG, Solingen, Germany. Third Parties are explicitly prohibited from using any of the brandnames, logos or marks of any kind found there. This applies in particular to the internationally registered trademark "LUTZ BLADES exactly", which consists of words and graphic symbols. LUTZ will pursue all violations against trademark law regarding its trademarks.

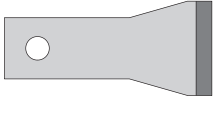
**Copyright:** © COPYRIGHT LUTZ GmbH & Co. KG, Solingen, Germany. All rights reserved. Copy, photos, graphics, technical drawings, layouts and other information used in all our publications and their arrangements on our LUTZ website are subject to copyright and other proprietary rights.

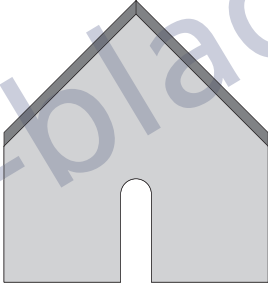
LUTZ allows the content of its websites to be viewed and downloaded exclusively for non-commercial use. This content may not be duplicated, presented, distributed or in any way used for publication of any kind or commercial use. This content may not be modified or used on other websites or networked computers without prior written approval by LUTZ GmbH & Co. KG.

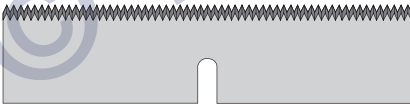
E & OE. Subject to our general terms & conditions on the Internet at [www.lutz-blades.com](http://www.lutz-blades.com).

Ref.	Length (mm)	Width (mm)	Thickn. (mm)	Ref.	Length (mm)	Width (mm)	Thickn. (mm)	Ref.	Length (mm)	Width (mm)	Thickn. (mm)
	31.0	9.0	0.60		33.3	7.8	0.30		14.0	12.9	0.40
	250.0	28.0	1.00		46.0	24.0	0.80		46.5	24.2	1.00
	112.0	19.0	0.38		44.0	20.0	0.80		46.0	13.2	1.00
			0.40		60.0	64.0	1.20				
	40.5	8.2	0.40								
	108.0	25.4	0.51								
	499.0	20.0	1.00								



**CUTTING EDGE SHAPES**

For the definition of edge type and bevel configuration see the following matrix:

		single edged	double edged	convex	concave
one sided					
		a	g	m	t
		b	h	n	u
		c	i	o	v
		d	j	p	w
		e	k	r	x
two sided		f	l	s	y

**Proprietary rights:** The owner of all the brandnames used by LUTZ on its websites is LUTZ GmbH & Co. KG, Solingen, Germany. Third Parties are explicitly prohibited from using any of the brandnames, logos or marks of any kind found there. This applies in particular to the internationally registered trademark "LUTZ BLADES exactly", which consists of words and graphic symbols. LUTZ will pursue all violations against trademark law regarding its trademarks.

**Copyright:** © COPYRIGHT LUTZ GmbH & Co. KG, Solingen, Germany. All rights reserved. Copy, photos, graphics, technical drawings, layouts and other information used in all our publications and their arrangements on our LUTZ website are subject to copyright and other proprietary rights.

LUTZ allows the content of its websites to be viewed and downloaded exclusively for non-commercial use. This content may not be duplicated, presented, distributed or in any way used for publication of any kind or commercial use. This content may not be modified or used on other websites or networked computers without prior written approval by LUTZ GmbH & Co. KG.

E & OE. Subject to our general terms & conditions on the Internet at [www.lutz-blades.com](http://www.lutz-blades.com).

## COATINGS

Sharpness  
Quality of the cut

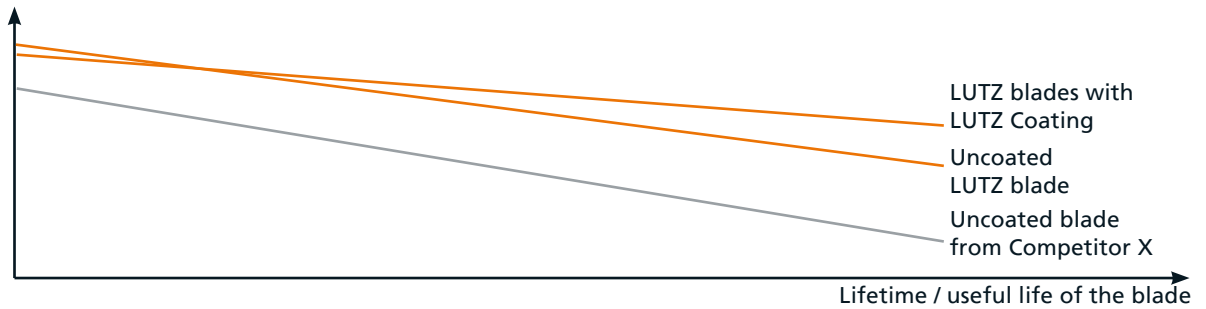

The LUTZ coatings range includes the following choices:

### TiN

Standard hard coating with tough resistance to wear with a relatively high coefficient of friction (compared with steel as a reference material: 0.4 to 0.7), usually gold coloured, safe use at up to approx. 300 °C

### TiC

Has lower resistance to wear than TiN and a considerably lower coefficient of friction (compared with steel as a reference material: 0.3 to 0.5), usually charcoal grey

### TiCN

Takes a position between the high wear resistance of TiN and the low coefficient of friction of TiC, relative position between TiN and TiC depending on C and N content, usually charcoal grey

### TiAlN

Has greater resistance to oxidation than TiN with a comparable coefficient of friction, usually charcoal grey

### ZrN

With wear resistance similar to TiN, but with a more dense morphology than TiN and, as a result, more resistant to pitting under comparable load, usually steel colour

### CrN

Lower wear resistance than TiN. The advantage of CrN is it has a lower inherent tension than TiN. As a result, can be used for applications with high bending loads

### DLC

Has a high wear resistance and a low coefficient of friction (approx. 0.1 compared with steel as a reference); sensitive to impacts and high temperatures (between 100° and 300 °C depending on structure)

### Teflon® (PTFE)

Non-stick coating Teflon® (PTFE), very low static friction allows a smooth cut, therefore a popular coating for medical devices. Because of the low surface tension almost no contamination from the cut goods. Acid and base-resistant, not suitable in combination with Na (sodium). Temperature resistant up to 250°C (480°F). Medium wear resistance

### Coloured lacquer

Applied to entire surface, acts as an aid to sorting different material thicknesses and as anticorrosion protection

### Blueing and blackening

Applied to entire surface, some anticorrosion protection and thickness protection, also aids differentiation

**Proprietary rights:** The owner of all the brandnames used by LUTZ on its websites is LUTZ GmbH & Co. KG, Solingen, Germany. Third Parties are explicitly prohibited from using any of the brandnames, logos or marks of any kind found there. This applies in particular to the internationally registered trademark "LUTZ BLADES exactly", which consists of words and graphic symbols. LUTZ will pursue all violations against trademark law regarding its trademarks.  
**Copyright:** © COPYRIGHT LUTZ GmbH & Co. KG, Solingen, Germany. All rights reserved. Copy, photos, graphics, technical drawings, layouts and other information used in all our publications and their arrangements on our LUTZ website are subject to copyright and other proprietary rights.  
LUTZ allows the content of its websites to be viewed and downloaded exclusively for non-commercial use. This content may not be duplicated, presented, distributed or in any way used for publication of any kind or commercial use. This content may not be modified or used on other websites or networked computers without prior written approval by LUTZ GmbH & Co. KG.  
E & OE. Subject to our general terms & conditions on the Internet at [www.lutz-blades.com](http://www.lutz-blades.com).

## CHOICE OF MATERIAL

We produce blades in thicknesses between 0.06 and 3.0 mm and with final hardness ratings of 40 - 85 HRc.

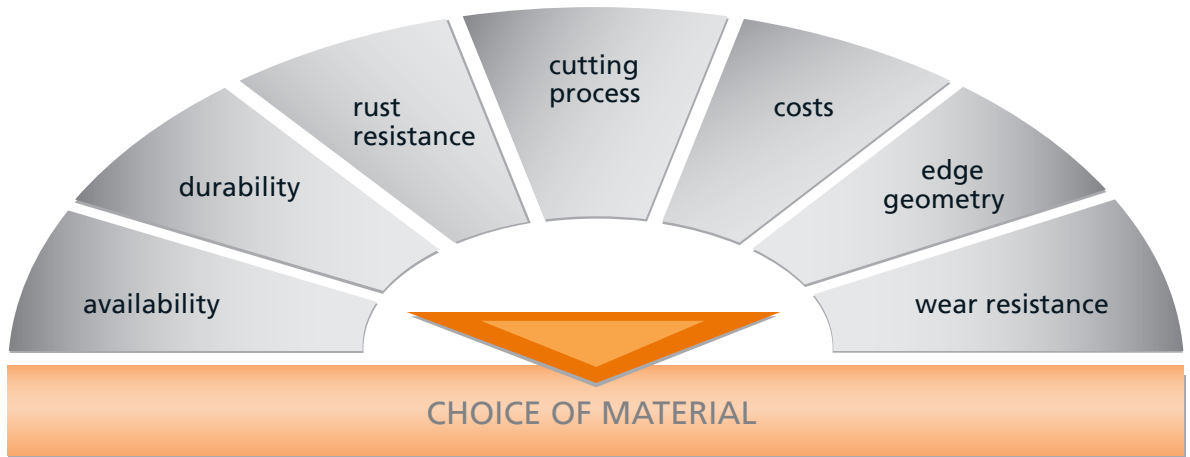

Our range of materials includes:

- » Carbon steels
- » Stainless and rust-resistant steels
- » Highspeed steels (HSS)
- » Tool steels
- » Tungsten carbide
- » Ceramics

**Proprietary rights:** The owner of all the brandnames used by LUTZ on its websites is LUTZ GmbH & Co. KG, Solingen, Germany. Third Parties are explicitly prohibited from using any of the brandnames, logos or marks of any kind found there. This applies in particular to the internationally registered trademark "LUTZ BLADES exactly", which consists of words and graphic symbols. LUTZ will pursue all violations against trademark law regarding its trademarks.

**Copyright:** © COPYRIGHT LUTZ GmbH & Co. KG, Solingen, Germany. All rights reserved. Copy, photos, graphics, technical drawings, layouts and other information used in all our publications and their arrangements on our LUTZ website are subject to copyright and other proprietary rights.

LUTZ allows the content of its websites to be viewed and downloaded exclusively for non-commercial use. This content may not be duplicated, presented, distributed or in any way used for publication of any kind or commercial use. This content may not be modified or used on other websites or networked computers without prior written approval by LUTZ GmbH & Co. KG.

E & OE. Subject to our general terms & conditions on the Internet at [www.lutz-blades.com](http://www.lutz-blades.com).